

IFC-320(E)(C)

Intelligent Addressable Fire Alarm System



General

In stand-alone or network configurations, the IFC-320 meet virtually every application requirement.

Designed with modularity and ease of system planning, the IFC-320 can be configured with just a few devices for small building applications, or for a large campus or high-rise application. Simply add additional peripheral equipment to suit the application. For Canadian applications with IFC-320C, an optional ACM Series annunciator can be mounted in the same cabinet (up to 48 zones/points, order separately).

The FireWatch Series internet monitoring modules IPDACT2 and IPDACT-2UD permit monitoring of alarm signals over the Internet, saving the monthly cost of two dedicated business telephone lines. Although not required, the secondary telephone line may be retained providing backup communication over the public switched telephone line.

NOTE: Unless called out with a version-specific “C” or “E” at the end of the part number, “IFC-320” refers to models IFC-320, IFC-320C, and IFC-320E; similarly, “JCPU-320” refers to the main circuit board for JCPU-320, JCPU-320C, and JCPU-320E.

Features

- Listed to UL Standard 864, 9th edition.
- One isolated intelligent Signaling Line Circuit (SLC) Style 4, 6 or 7.
- Up to 159 detectors (any mix of ion, photo, thermal, or multi-sensor) and 159 modules (Addressable pull stations, normally open contact devices, two-wire smoke, notification, or relay). 318 devices maximum.
- Standard 80-character display.
- Network options:
 - High-speed network for up to 200 nodes (IFC2-3030, IFC2-640, IFC-320(C), JNCA-2, JDVC, IFI, IFW, IFC-3030, IFC-640, and JNCA).
 - Standard network or up to 103 nodes (IFC-640, IFC2-640, IFC-320, IFC-3030, IFC2-3030, IFC-200, IFC-300/400, IFC-1010, IFC-2020, JDVC-EM, IFI, IFW, JNCA or JNCA-2 Network Annunciators). Up to 54 nodes when DVC is used in network paging.
- 6.0 amp power supply with four Class A/B built-in Notification Appliance Circuits (NAC). Selectable System Sensor, Wheelock, or Gentex strobe synchronization.
- Built-in Alarm, Trouble, Security, and Supervisory relays.
- VeriFire® Tools online or offline programming utility. Upload/Download, save, store, check, compare, and simulate panel databases. Upgrade panel firmware.
- Autoprogramming and Walk Test reports.
- Optional universal 318-point DACT.
- 80-character remote annunciators (up to 32).
- EIA-485 annunciators, including custom graphics.
- Printer interface (80-column and 40-column printers).
- History file with 800-event capacity in nonvolatile memory, plus separate 200-event alarm-only file.
- Alarm Verification selection per point, with tally.
- Autoprogramming and Walk Test reports.
- Presignal/Positive Alarm Sequence (PAS).
- Silence inhibit and Auto Silence timer options.



IFC-320

- NAC coding functions:
 - March time.
 - Temporal.
 - California two-stage coding.
 - Canadian two-stage.
 - Strobe synchronization.
- Field-programmable on panel or on PC, with VeriFire Tools program check, compare, simulate.
- Full QWERTY keypad.
- Battery charger supports 18 – 200 amp hour batteries
- Non-alarm points for lower priority functions.
- Remote ACK/Signal Silence/System Reset/Drill via monitor modules.
- Automatic time control functions, with holiday exceptions.
- Surface Mount Technology (SMT) electronics.
- Extensive, built-in transient protection.
- Powerful Boolean logic equations.

FLASHSCAN® INTELLIGENT FEATURES:

- Poll up to 318 devices in less than two seconds.
- Activate up to 159 outputs in less than five seconds.
- Multicolor LEDs blink device address during Walk Test.
- Fully digital, high-precision protocol (U.S. Patent 5,539,389).
- Manual sensitivity adjustment — nine levels.
- Pre-alarm intelligent sensing — nine levels.
- Day/Night automatic sensitivity adjustment.
- Sensitivity windows:
 - Ion – 0.5 to 2.5%/foot obscuration.
 - Photo – 0.5 to 2.35%/foot obscuration.
 - Laser (VIEW®) – 0.02 to 2.0%/foot obscuration.
 - Acclimate – 0.5 to 4.0%/foot obscuration.
 - COPTIR – 1.0 to 4.0%/foot obscuration.
- Drift compensation (U.S. Patent 5,764,142).
- Degraded mode — in the unlikely event that the JCPU-320 microprocessor fails, FlashScan detectors revert to degraded operation and can activate the JCPU-320 NAC circuits and

alarm relay. Each of the four built-in panel circuits includes a Disable/Enable switch for this feature.

- Multi-detector algorithm involves nearby detectors in alarm decision (U.S. Patent 5,627,515).
- Automatic detector sensitivity testing (NFPA-72 compliant).
- Maintenance alert (two levels).
- Self-optimizing pre-alarm.

**2951J-COPTIR COPTIR
ADVANCED MULTI-CRITERIA DETECTOR**

- Detects all four major elements of a fire (smoke, heat, CO, and flame).
- Automatic drift compensation of smoke sensor and CO cell.
- High nuisance-alarm immunity.
- Six sensitivity levels.

**7351J VIEW (VERY INTELLIGENT EARLY WARNING)
SMOKE DETECTION TECHNOLOGY:**

- Revolutionary spot laser design.
- Advanced intelligent sensing algorithms differentiate between smoke and non-smoke signals (U.S. Patent 5,831,524).
- Addressable operation pinpoints the fire location.
- No moving parts to fail or filters to change.
- Early warning performance comparable to the best aspiration systems at a fraction of the lifetime cost.

2951TMJ ACCLIMATE

LOW-PROFILE INTELLIGENT MULTI-SENSOR:

- Detector automatically adjusts sensitivity levels without operator intervention or programming. Sensitivity increases with heat.
- Microprocessor-based technology; combination photo and thermal technology.
- FlashScan or classic mode compatible.
- Low-temperature warning signal at 40°F ± 5°F (4.44°C ± 2.77°C).

RELEASING FEATURES:

- Ten independent hazards.
- Sophisticated cross-zone (three options).
- Delay timer and Discharge timers (adjustable).
- Abort (four options).
- Low-pressure CO₂ listed.

**HIGH-EFFICIENCY OFFLINE SWITCHING
3.0 AMP POWER SUPPLY (6.0 A IN ALARM):**

- 120 VAC (IFC-320/IFC-320C); 240 VAC (IFC-320E).
- Displays battery current/voltage on panel (with display).

**FlashScan, Exclusive
World-Leading Detector Protocol**

At the heart of the IFC-320 is a set of detection devices and device protocol — FlashScan (U.S. Patent 5,539,389). Flash-

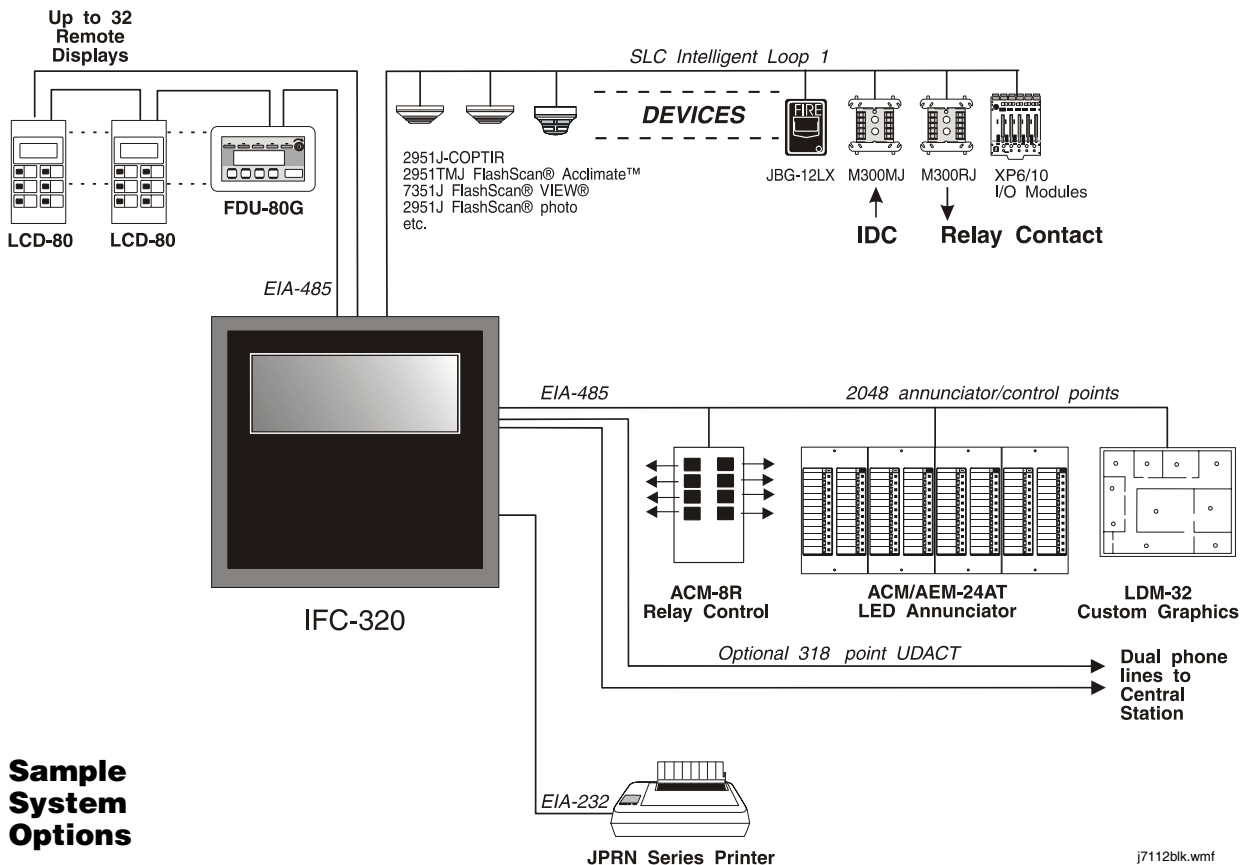

**Sample
System
Options**

j7112blk.wmf

Scan is an all-digital protocol that gives superior precision and high noise immunity.

In addition to providing quick identification of an active input device, this new protocol can also activate many output devices in a fraction of the time required by competitive protocols. This high speed also allows the IFC-320 to have the largest device per loop capacity in the industry — 318 points — yet every input and output device is sampled in less than two seconds. The microprocessor-based FlashScan detectors have bicolor LEDs that can be coded to provide diagnostic information, such as device address during Walk Test.

Intelligent Sensing

Intelligent sensing is a set of software algorithms that provides the IFC-320 with industry-leading smoke detection capability. These complex algorithms require many calculations on each reading of each detector, and are made possible by the high-speed microcomputer used by the IFC-320.

Drift Compensation and Smoothing: Drift compensation allows the detector to retain its original ability to detect actual smoke, and resist false alarms, even as dirt accumulates. It reduces maintenance requirements by allowing the system to automatically perform the periodic sensitivity measurements required by NFPA 72. Smoothing filters are also provided by software to remove transient noise signals, such as those caused by electrical interference.

Maintenance Warnings: When the drift compensation performed for a detector reaches a certain level, the performance of the detector may be compromised, and special warnings are given. There are three warning levels: (1) Low Chamber value; (2) Maintenance Alert, indicative of dust accumulation that is near but below the allowed limit; (3) Maintenance Urgent, indicative of dust accumulation above the allowed limit.

Sensitivity Adjust: Nine sensitivity levels are provided for alarm detection. These levels can be set manually, or can change automatically between day and night. Nine levels of pre-alarm sensitivity can also be selected, based on predetermined levels of alarm. Pre-alarm operation can be latching or self-restoring, and can be used to activate special control functions.

Self-Optimizing Pre-Alarm: Each detector may be set for “Self-Optimizing” pre-alarm. In this special mode, the detector “learns” its normal environment, measuring the peak analog readings over a long period of time, and setting the pre-alarm level just above these normal peaks.

Cooperating Multi-Detector Sensing: A patented feature of intelligent sensing is the ability of a smoke sensor to consider readings from nearby sensors in making alarm or pre-alarm decisions. Without statistical sacrifice in the ability to resist false alarms, it allows a sensor to increase its sensitivity to actual smoke by a factor of almost two to one.

Field Programming Options

Autoprogram. This timesaving feature is a special software routine. The FACP “learns” what devices are physically connected and automatically loads them in the program with default values for all parameters. Requiring less than one minute to run, this routine allows the user to have almost immediate fire protection in a new installation, even if only a portion of the detectors are installed.

Keypad Program Edit (with KDM-R2) The IFC-320 has the exclusive feature of the product line of program creation and editing capability from the front panel keypad, **while continuing to provide fire protection.** The architecture of the IFC-320 software is such that each point entry carries its own program, including control-by-event links to other points. This allows the program to be entered with independent per-point segments, while the IFC-320 simultaneously monitors other (already installed) points for alarm conditions.

VeriFire Tools is an offline programming and test utility that can greatly reduce installation programming time, and increase confidence in the site-specific software. It is Windows®-based and provides technologically advanced capabilities to aid the installer. The installer may create the entire program for the IFC-320 in the comfort of the office, test it, store a backup file, then bring it to the site and download from a laptop into the panel.

Placement of Equipment in Chassis and Cabinet

The following guidelines outline the IFC-320’s flexible system design.

Wiring: When designing the cabinet layout, consider separation of power-limited and non-power-limited wiring as discussed in the IFC-320 Installation Manual.

It is critical that all mounting holes of the IFC-320 are secured with a screw or standoff to ensure continuity of Earth Ground.

Networking: If networking two or more control panels, each unit requires a Network Control Module (see “Network Options” on page 4). These modules can be installed in any option board position (see manual), and additional option boards can be mounted in front of them.

KDM-R2 Controls and Indicators

Program Keypad: QWERTY type (keyboard layout).

12 LED Indicators: Power; Fire Alarm; Pre-Alarm; Security; Supervisory; System Trouble; Signals Silenced; Points Disabled; Control Active; Abort; Pre-Discharge; Discharge.

Keypad Switch Controls: Acknowledge/Scroll Display; Signal Silence; Drill; System Reset; Lamp Test.

LCD Display: 80 characters (2 x 40) with long-life LED backlight.

Configuration Guidelines

The IFC-320 system ships assembled; description and some options follow.

Note: Stand-alone and network systems require a main display. On stand-alone systems, the panel’s keypad provides the required display. On network systems (two or more networked fire panel nodes), at least one JNCA-2, IFW, or IFI annunciation device is required.

IFC-320: The standard, factory-assembled IFC-320 system includes the following components: one CPU-320 control panel mounted on chassis (120 V operation — ships with grounding cable, battery interconnect cables, and document kit); includes integral power supply mounted to the CPU-320; one primary display KDM-R2 keypad/display; and one cabinet for surface or semi-flush mounting. *Purchase batteries separately. One or two option boards may be mounted inside the IFC-320 cabinet; additional option boards can be utilized in remote cabinets.*

IFC-320R: Same as IFC-320 above, but in red enclosure.

IFC-320C: Based on IFC-320 above, IFC-320C adds a standard visible annunciator as required for Canadian applications. ULC listed. For French-language version, order IFC-320C-FR. *See Canadian applications manual addendum 52858.*

IFC-320E: Same as IFC-320 above, but with 240 V operation.

TR-320: Trim ring for the IFC-320 cabinet.

Option Modules

FCPS-24S6/-24S8: Remote six-amp and eight-amp power supplies with battery charger. In Canadian applications, for use only as a NAC expander. *See JCI-6927.*

COMPATIBLE DEVICES, EIA-232 PORTS

JPRN-6: 80-column printer. *See JCI-6956.*

VS4095/5: Printer, 40-column, 24 V. Mounted in external back-box. (Not ULC-listed.)

COMPATIBLE DEVICES, EIA-485 PORTS

ACM-24AT: ACS annunciator – up to 96 points of annunciation with Alarm or Active LED, Trouble LED, and switch per circuit. Active/Alarm LEDs can be programmed (by powered-up switch selection) by point to be red, green, or yellow; the Trouble LED is always yellow. *See JCI-6862.*

AEM-24AT: Same LED and switch capabilities as ACM-24AT, expands the ACM-24AT to 48, 72, or 96 points. *See JCI-6862.*

ACM-48A: ACS annunciator – up to 96 points of annunciation with Alarm or Active LED per circuit. Active/Alarm LEDs can be programmed (by powered-up switch selection) in groups of 24 to be red, green, or yellow. Expandable to 96 points with one AEM-48A. *See JCI-6862.*

AEM-48A: Same LED capabilities as ACM-48A, expands the ACM-48A to 96 points. *See JCI-6862.*

TM-4: Transmitter Module. Includes three reverse-polarity circuits and one municipal box circuit; mount on IFC-320 chassis or remotely. *See JCI-6860.*

LCD-80/FDU-80G: 80-character, backlit LCD display. Mounts up to 6,000 ft. (1828.8 m) from panel. Up to 32 per FACP. *See LCD-80/80TM (JCI-3198) and FDU-80G (JCI-6820).*

LDM: Lamp Driver Modules LDM-32, LDM-E32, and LDM-R32; remote custom driver modules. *See LDM data sheet, JCI-60011.*

ACM-8R: Remote Relay Module with eight Form-C contacts. Can be located up to 6,000 ft. (1828.8 m) from panel on four wires. *See ACM-8R data sheet, JCI-60044.*

APS2-6R: Auxiliary Power Supply. Provides up to 6.0 amperes of power for peripheral devices. Includes battery input and transfer relay, and overcurrent protection. Mounts on two of four positions on a CHS-4L or CHS-4 chassis. *See JCI-60061.*

SCS: Smoke control stations SCS-8, SCE-8, with lamp drivers SCS-8L, SCE-8L; eight (expandable to 16) circuits. *See SCS data sheet JCI-60050.*

UDACT: Universal Digital Alarm Communicator Transmitter, 636 channel. *See JCI-60047.*

UZC-256: Programmable Universal Zone Coder provides positive non-interfering successive zone coding. Microprocessor-controlled, field-programmable from IBM®-compatible PCs (requires optional programming kit). Mounts in **BB-UZC**. *See JCI-60041.*

COMPATIBLE INTELLIGENT DEVICES

BEAMHK: Heating kit for transmitter/receiver unit of FSB-200(S) below. *See JCI-60189.*

BEAMHRK: Heating kit for use with the reflector of FSB-200(S) below. *See JCI-60189.*

BEAMLRK: Long-range accessory kit, FSB-200(S) below. *See JCI-60189.*

BEAMMRK: Multi-mount kit, FSB-200(S) below. *See JCI-60189.*

BEAMSMK: Surface-mount kit, FSB-200(S) below. *See JCI-60189.*

FSB-200: Intelligent beam smoke detector. *See JCI-60189.*

FSB-200S: Intelligent beam smoke detector with integral sensitivity test. *See JCI-60189.*

2951J-COPTIR: FlashScan COPTIR Advanced Multi-Criteria Detector. *See JCI-60472.*

1951J: Low-profile FlashScan ionization detector. *See JCI-6934.*

2951J: Low-profile FlashScan photoelectric detector. *See JCI-6935.*

2951TJ: Low-profile FlashScan photoelectric detector with 135°F (57°C) thermal. *See JCI-6935.*

5951J: FlashScan thermal detector 135°F (57°C). *See JCI-6936.*

5951RJ: FlashScan thermal detector 135°F (57°C) with rate-of-rise. *See JCI-6936.* **5951HJ:** FlashScan 190°F (88°C) high-temperature thermal detector. *See JCI-6936.*

DNR: InnovairFlex low-flow non-relay duct-detector housing (order 2951J separately). Replaces DH300PL/DH300RPL. *See JCI-60432.*

DNRW: Same as above with NEMA-4 rating, watertight. *See JCI-60432.*

2951TMJ: FlashScan Acclimate low-profile multi-sensor detector. *See JCI-6937.*

7351J: FlashScan VIEW laser photo detector. *See JCI-60081.*

B224R: Low-profile relay base. *See JCI-60056.*

B224BI: Isolator base for low-profile detectors. *See JCI-60056.*

B210LPJ: Low-profile base. Standard U.S. style. *See JCI-60056.*

B501J: European-style, 4" (10.16 cm) base. *See JCI-60056.*

B501JBP: Flangeless mounting base, ULC Listed.

B501BH-2: Standard sounder base, steady tone, includes B501 base above. *See JCI-60056.*

B501BHT-2: Temporal tone sounder base. *See JCI-60056.*

B200SR: Intelligent sounder base, Temporal 3 or Continuous tone. *See JCI-60056.*

M300MJ: FlashScan monitor module. *See JCI-6720.*

M300DH: FlashScan dual monitor module. *See JCI-6720.*

M302MJ: FlashScan two-wire detector monitor module. *See JCI-6720.*

M301MJ: FlashScan miniature monitor module. *See JCI-6720.*

M300CJ-REL: FlashScan releasing control module.

M300CJ: FlashScan NAC control module. *See JCI-6724.*

M300RJ: FlashScan relay module. *See JCI-6724.*

JBG-12LX: Manual pull station, addressable. *See JCI-60079.*

J-MPS series: Manual pull stations, addressable and conventional. For use in Canada only. *See JCI-60419.*

M500XJ: Isolator module. *See JCI-60114.*

XP6-C: FlashScan six-circuit supervised control module. *See JCI-6924.*

XP6-MA: FlashScan six-zone interface module; connects intelligent alarm system to two-wire conventional detection zone. *See JCI-6925.*

XP6-R: FlashScan six-relay (Form-C) control module. *See JCI-6926.*

XP10-M: FlashScan ten-input monitor module. *See JCI-6923.*

NETWORK OPTIONS

NCM-W, NCM-F: Network Communications Modules. Wire and multi-mode fiber versions available. *See JCI-6861.*

HS-NCM-W/MF/SF/WMF/WSF/MFSF: High-speed network communications modules. Wire, single-mode fiber, multi-mode fiber, and media conversion models are available. *See DN-60454. See JCI-60482.*

RPT-W, RPT-F, RPT-WF: Network repeater board with wire connection (RPT-W), fiber connection (RPT-F), or allowing a change in media type between wire and fiber (RPT-WF). *See JCI-6861.*

IFI-W: UL-listed graphics PC workstation for NOTI•FIRE•NET with wire media. Includes NFN Gateway wire version (JNFN-GW-PC-W) and 19" color flat-screen LCD monitor. Each IFI workstation consumes one of 103 network addresses. *See JCI-60422.*

IFI-HSN-W: UL-listed graphics PC workstation for wire high-speed network. Includes high-speed NFN Gateway (JHSN-GW-PC-W) and 19" color flat-screen LCD monitor. Each IFI consumes one of up to 200 network addresses. See *JCI-60422*.

IFI-F: UL-listed graphics PC workstation for standard network with fiber media. Includes NFN Gateway wire version (JNFN-GW-PC-F) and 19" color flat-screen LCD monitor. Each IFI workstation consumes one of 103 network addresses. See *JCI-60422*.

IFI-HSN-SF: UL-listed graphics PC workstation for single-mode-fiber high-speed network. Includes HS-NFN Gateway (JHSN-GW-PC-SF) and 19" color flat-screen LCD monitor. Each IFI consumes one of up to 200 network addresses. See *JCI-60422*.

IFI-HSN-MF: UL-listed graphics PC workstation for multi-mode-fiber high-speed network. Includes HS-NFN Gateway (JHSN-GW-PC-MF) and 19" color flat-screen LCD monitor. Each IFI consumes one of up to 200 network addresses. See *JCI-60422*.

JNFN-GW-EM, JNFN-GW-EM-3: NFN Gateway, embedded.

OTHER OPTIONS

IPDACT-2/2UD Internet Monitoring Module: Mounts in IPENC enclosure. Connects to primary and secondary DACT telephone output ports for internet communications over customer-provided ethernet connection. Requires compatible Teldat Visor-ALARM Central Station Receiver. Can use DHCP or static IP. See *DN-60408*.

IPENC: External enclosure for IPDACT, includes IPBRKT mounting bracket; Red. For Black order IPENC-B.

Enclosure must be "close-nipple" to a panel no further than 6 in. (15 cm) via conduit. Required for IFC-320 applications.

IPSPLT: Y-adaptor option allow connection of both panel dialer outputs to one IPDACT-2/2UD cable input.

DPI-232: Direct Panel Interface, specialized modem for extending serial data links to remotely located FACPs and/or peripherals; mount on IFC-320 chassis. See *JCI-6870*.

JVeriFire-TCD: VeriFire Tools CD-ROM. Contains programming software for the IFC-320, JNCA-2. Includes local panel connection cable. See *JCI-6871*.

BAT Series: Batteries. IFC-320 utilizes two 12 volt, 18 to 200 AH batteries. This series of products replaces the previous PS Series. See *JCI-6933*.

JCI-LBB: Battery Box (required for batteries larger than 25 AH).

JCI-LBBR: Same as above, but red.

411: Slave Digital Alarm Communicator. See *JCI-60155*.

411UDAC: Digital Alarm Communicator. See *JCI-60205*.

IFC-320-RB: Replacement CPU. *NOTE: Keypad must be removed before shipping old unit out for repair.*

IFC-320-RBC-FR: Replacement CPU french. *NOTE: Keypad must be removed before shipping old unit out for repair.*

BB-UZC: Backbox for housing the UZC-256. Required for NFS-320 applications where the UZC will not fit in panel enclosure, black. For red, order BB-UZC-R.

SYSTEM SPECIFICATIONS

System Capacity

- Intelligent Signaling Line Circuits 1
- Intelligent detectors 159
- Addressable monitor/control modules 159
- Programmable internal hardware and output circuits 4
- Programmable software zones 99
- Special programming zones 14
- LCD annunciators per JCPU-320/-320E 32
- ACS annunciators per JCPU-320/-320E 32 addresses x 64 points

Specifications

- Primary input power, **JCPU-320 board:** 120 VAC, 50/60 Hz, 3.0 A. **JCPU-320E board:** 220/240 VAC, 50/60 Hz, 1.5 A.
- Total output 24 V power: 6.0 A in alarm.

NOTE: The power supply has a total of 6.0 A of available power. This is shared by all internal circuits.

- Standard notification circuits (4): 1.5 A each.
- Resettable regulated 24V power: 1.25 A.
- Two non-resettable regulated 24V power outputs. One at 1.25 A and the other at 0.50 A.
- Non-resettable 5V power: 0.15 A.
- Battery charger range: 18 AH – 200 AH. Use separate cabinet for batteries over 25 AH.
- Float rate: 27.6 V.

Cabinet Specifications

- IFC-320/IFC-320C cabinet dimensions: Backbox: 18.12 in. (46.025 cm) width; 18.12 in. (46.025 cm) height; 5.81 in. (14.76 cm) depth.
- Door: 18.187 in. (46.195 cm) width; 18.40 in. (46.736 cm) height; 0.75 in. (1.905 cm) depth.

When using trim ring TR-320, mount backbox with at least 1 inch (2.54 cm) between wall surface and front of backbox, to allow door to open fully past the trim ring. The TR-320 molding width is 0.905 in. (2.299 cm).

Temperature and Humidity Ranges

This system meets NFPA requirements for operation at 0 – 49°C/32 – 120°F and at a relative humidity 93% ± 2% RH (noncondensing) at 32°C ± 2°C (90°F ± 3°F). However, the useful life of the system's standby batteries and the electronic components may be adversely affected by extreme temperature ranges and humidity. Therefore, it is recommended that this system and its peripherals be installed in an environment with a normal room temperature of 15 – 27°C/60 – 80°F.

Agency Listings and Approvals

The listings and approvals below apply to the basic IFC-320 control panel. In some cases, certain modules may not be listed by certain approval agencies, or listing may be in process. Consult factory for latest listing status.

- **UL Listed:** file S1570
- **ULC Listed:** file S1570 (IFC-320C only, excludes IPDACT)
- **CSFM:** 7165-0554:153
- **MEA:** 128-07-E Vol. 4, **FDNY:** Certificate #60010
- **City of Chicago**

Standards

The IFC-320 complies with the following UL Standards and NFPA 72 Fire Alarm Systems requirements:

- **UL 864** (Fire).
- **UL 1076** (Burglary).
- **LOCAL** (Automatic, Manual, Waterflow and Sprinkler Supervisory).
- **AUXILIARY** (Automatic, Manual and Waterflow) (requires TM-4).
- **REMOTE STATION** (Automatic, Manual, Waterflow and Sprinkler Supervisory) (requires TM-4).
- **PROPRIETARY** (Automatic, Manual, Waterflow and Sprinkler Supervisory). *Not applicable for FM.*
- **CENTRAL STATION** (Automatic, Manual, Waterflow and Sprinkler Supervisory) (requires UDACT).
- **EMERGENCY VOICE/ALARM.**
- **OT, PSDN** (Other Technologies, Packet-switched Data Network)

NOTIFIRE•NET™ and **ONYXWorks™** are trademarks; and **Acclimate®**, **FlashScan®**, **NION®**, **NOTIFIER®**, **ONYX®**, **UniNet®**, **VeriFire®**, and **VIEW®** are registered trademarks of Honeywell International Inc. **Microsoft®** and **Windows®** are registered trademarks of Microsoft Corporation. **Echelon®** is a registered trademark of Echelon Corporation. **IBM®** is a registered trademark of IBM Corporation.
©2009. All rights reserved. Unauthorized use of this document is strictly prohibited.

This document is not intended to be used for installation purposes.
We try to keep our product information up-to-date and accurate.
We cannot cover all specific applications or anticipate all requirements.
All specifications are subject to change without notice.



Made in the U.S. A.

For more information, contact Johnson Controls Field Support Center.
507 East Michigan Street, Milwaukee, WI 53202 www.johnsoncontrols.com